

AQUAJOE®

INDESTRUCTIBLE METAL BASE **OSCILLATING SPRINKLER**

Model SJI-OMS16-RM

**THANKS FOR YOUR PURCHASE
OF A REMANUFACTURED PRODUCT.**

To make sure you get the most out of your product, be sure to register online at

sunjoe.com

to enjoy full product support.

PASTE UPC LABEL HERE

If you have any questions or comments,
please call the Snow Joe® + Sun Joe® customer service department at:

1-866-SNOWJOE (1-866-766-9563)

AQUAJOE®

INDESTRUCTIBLE METAL BASE **OSCILLATING SPRINKLER**

Model SJI-OMS16-RM

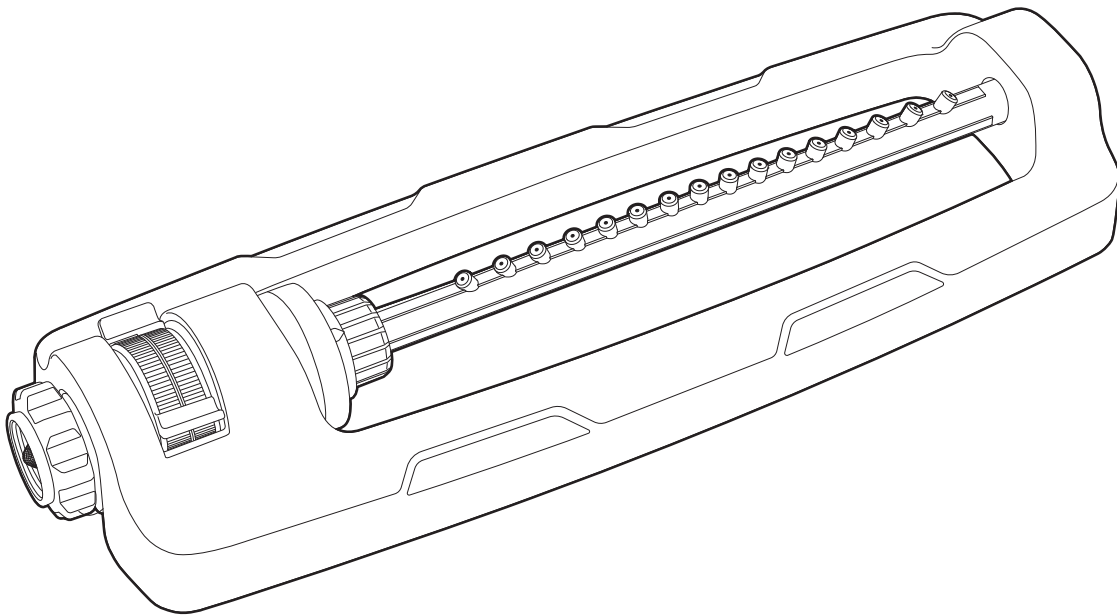

If you have any questions or comments,
please call the Snow Joe® + Sun Joe® customer service department at:

1-866-SNOWJOE (1-866-766-9563)

Know Your Sprinkler

- 1. Base
- 2. Spray nozzles (16)
- 3. Oscillator tube
- 4. Hose-end
- 5. Sliding tabs
- 6. Inlet filter
- 7. Cleaning pin

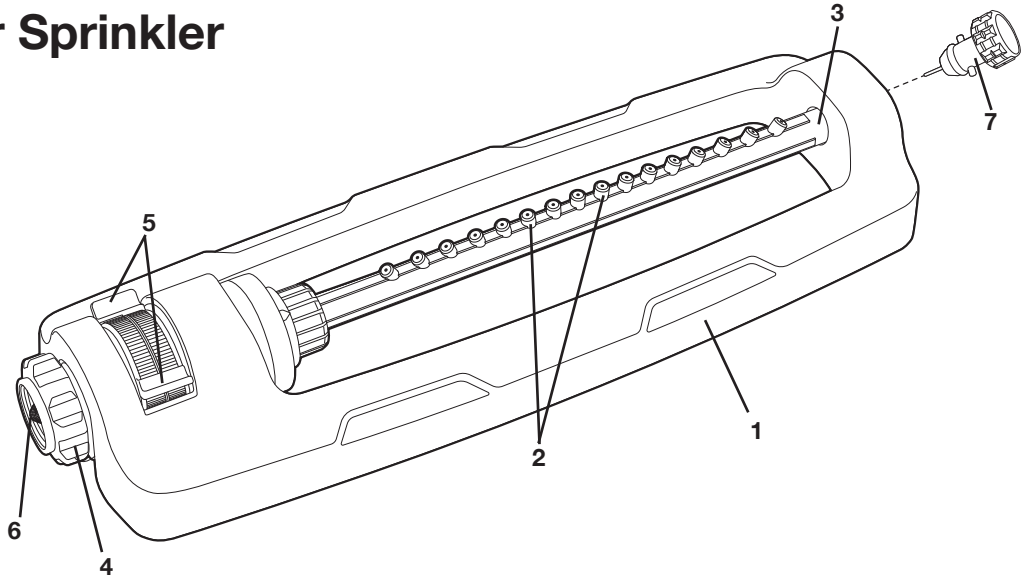

Technical Data

Plastic Nozzle Heads.....	16	Spray Distance Max	70 ft (21 m)
Fit Standard Garden Hose.....	Yes	Spray Width Max.....	37.8 ft (11.5 m)
Adjustable Range Control	Yes	Max Pressure*	120 PSI
Coverage Max	3600 sq ft (335 m ²)	Max Flow	6.65 GPM
		Weight	1.41 lbs (0.64 kg)

* Peak pressure at initial discharge; working pressure under typical load is 60 PSI.

Operation

Use sliding tabs to select desired position and take advantage of the sprinkler's adjustable range control (Fig.1). Refer to (Fig. 2) to see the different sprinkler options.

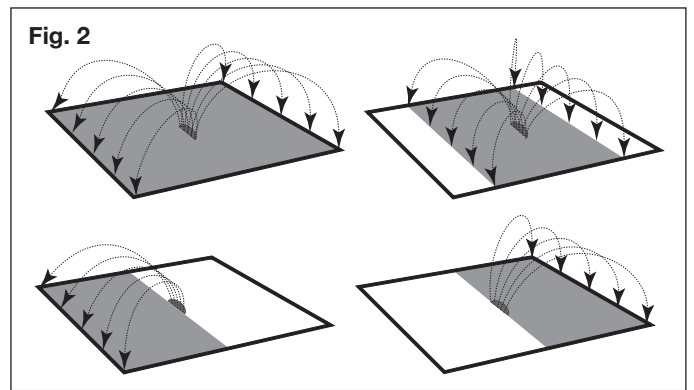
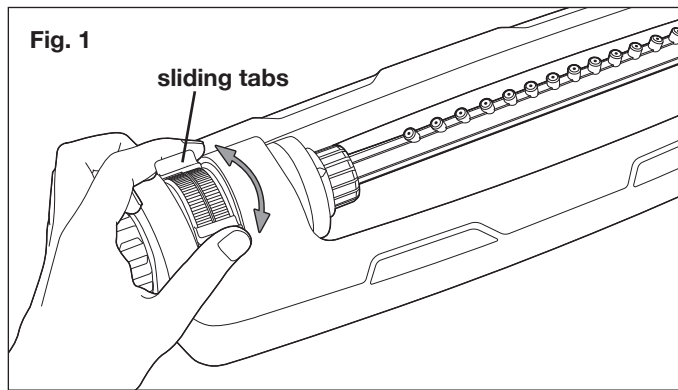

Watering Tips

Water only when necessary, preferably in the morning to minimize water loss through evaporation. To promote deep root growth, water deeply but as infrequently as possible. Watch water application to avoid water run-off.

Maintenance + Care

Follow the steps below if the sprinkler stops working or exhibits poor water quality due to debris or dirt build-up.

1. Remove the inlet filter from the hose-end of the oscillator and run under water (Fig. 3).

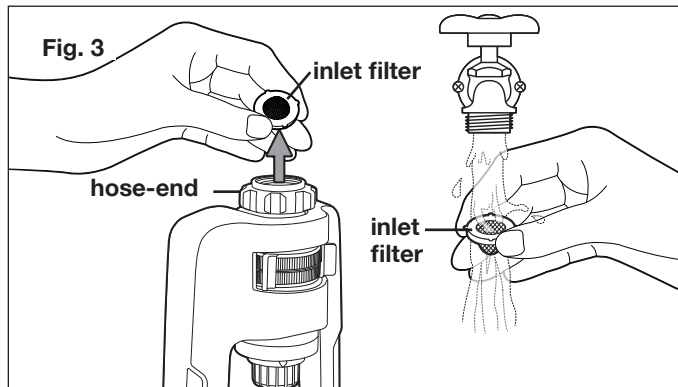

2. Remove the cleaning pin from the opposite end of the oscillator (Fig. 4).

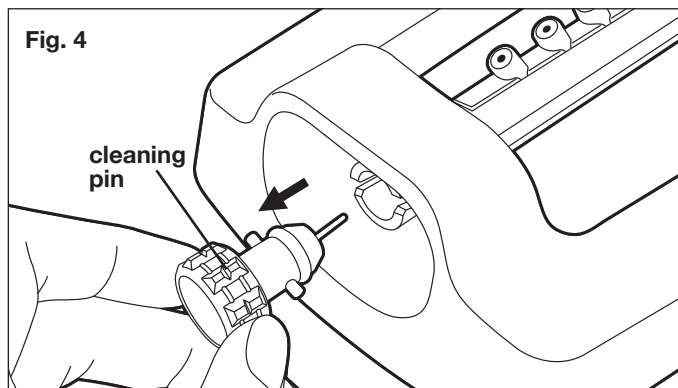

3. To flush, connect the oscillator to a spigot. Turn on the faucet and while the water continues running, spin the tube gently back and forth for few minutes. Then screw the inlet filter firmly back in place (Fig. 5)

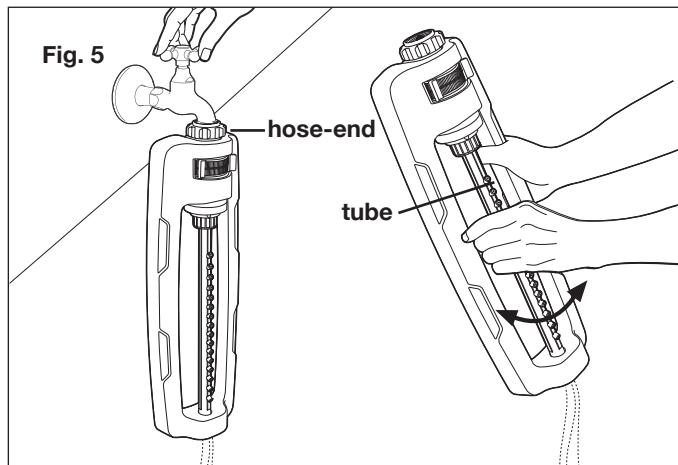

4. Use the provided cleaning pin to clear any clogs from the spray nozzles. Fit cleaning pin firmly back in place before using the sprinkler (Fig. 6).

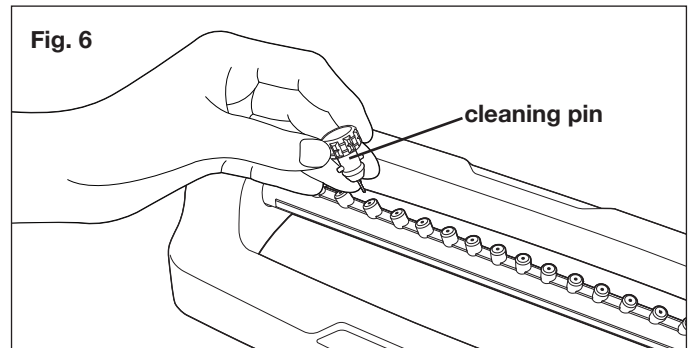

Storage

Drain the sprinkler after use. DO NOT allow water to freeze in the sprinkler (Fig. 7).

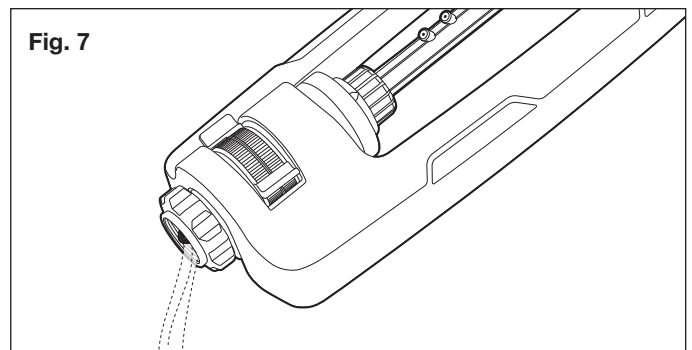

Service + Support

If your Aqua Joe® SJI-OMS16-RM oscillating sprinkler requires service or maintenance, please call Snow Joe® + Sun Joe® customer service at 1-866-SNOWJOE (1-866-766-9563) for assistance.

Model + Serial Numbers

When contacting the company or arranging service from an authorized dealer, you will need to provide the model and serial numbers, which can be found on the decal located on the sprinkler. Copy these numbers into the space provided below.

Record the following numbers from the housing or handle of your new product:

Model #: _____

S | J | I | - | O | M | S | 1 | 6 | - | R | M | _____

Serial #: _____



SNOW JOE® + SUN JOE® REFURBISHED GOODS WARRANTY

GENERAL CONDITIONS:

Snow Joe® + Sun Joe® operating under Snow Joe®, LLC warrants this refurbished product to the original purchaser for 90 days against defects in material or workmanship when used for normal residential purposes. If a replacement part or product is needed, it will be sent free of charge to the original purchaser except as noted below.

The duration of this warranty applies only if the product is put to personal use around the household. It is the owner's responsibility to correctly perform all maintenance and minor adjustments explained in the owner's manual.

HOW TO OBTAIN YOUR REPLACEMENT PART OR PRODUCT:

To obtain a replacement part or product, please visit snowjoe.com/help or email us at help@snowjoe.com for instructions. Please be sure to register your unit beforehand to speed up this process. Certain products may require a serial number, typically found on the decal affixed to the housing or guard of your product. All products require a valid proof of purchase.

EXCLUSIONS:

- Wearing parts like belts, augers, chains and tines are not covered under this warranty. Wearing parts can be purchased at snowjoe.com or by calling 1-866-SNOWJOE (1-866-766-9563).
- Batteries are covered in full for 90-days from the date of purchase.

Snow Joe® + Sun Joe® may from time to time change the design of its products. Nothing contained in this warranty shall be construed as obligating Snow Joe® + Sun Joe® to incorporate such design changes into previously manufactured products, nor shall such changes be construed as an admission that previous designs were defective.

This warranty is intended to cover product defects only. Snow Joe®, LLC is not liable for indirect, incidental or consequential damages in connection with the use or misuse of the Snow Joe® + Sun Joe® products covered by this warranty. This warranty does not cover any cost or expense incurred by the purchaser in providing substitute equipment or service during reasonable periods of malfunction or non-use of this product while waiting for a replacement part or unit under this warranty. Some states do not allow exclusions of incidental or consequential damages so the above exclusions may not apply in all states. This warranty may give you specific legal rights in your state.

HOW TO REACH US:

We're here to help Monday through Friday from 9AM to 7PM EST and Saturday and Sunday 9AM to 4PM. You can reach us at 1-866-SNOWJOE (1 866-766-9563), online at snowjoe.com, via email at help@snowjoe.com or tweet us @snowjoe.

EXPORTS:

Customers who have purchased Snow Joe® + Sun Joe® products exported from the United States and Canada should contact their Snow Joe® + Sun Joe® distributor (dealer) to obtain information applicable to your country, province or state. If for any reason, you are not satisfied with the distributor's service, or if you have difficulty obtaining warranty information, contact your Snow Joe® + Sun Joe® seller. If in the event your efforts are unsatisfactory, please reach out to us directly.



sunjoe.com